



KLAUER
MANUFACTURING CO.

**RESIDENTIAL STEEL SIDING
INSTALLATION MANUAL**

ABOUT THIS MANUAL

We suggest you review this entire manual before beginning your installation. As you read, you will want to refer to the drawing on page 8 to familiarize yourself with commonly used industry terms. You may also wish to cross-check various sections of the manual as you read.

Installing metal siding can be fairly simple if you follow the instructions in this manual. Each section is designed to guide you through every step of the job by providing practical advice based on years of industry practice and experience. Please note, however, that this manual is designed to help the qualified siding installer; it is not intended for use by homeowners.

The techniques discussed in this manual are illustrative of the basic procedures. They are not intended to be fully exhaustive and definitive. Other methods may be used by qualified installers with equal success.

The best method is dependent on the specific construction of the building being worked on, the brand and type of siding used and the particular skills of the individual applicator.

Although this manual is based on the best information and experience currently available in the industry, Klauer Manufacturing Company does not make any representation or warranty, express or implied (whether of merchantability or of fitness for a particular use or purpose) with respect to any tools, material, techniques or procedures referred to herein.

Always remember to use licensed contractors who understand local building codes as these codes may vary from one region to another.

Handle siding with care. Steel siding has sharp edges. Make sure product is stored flat with support under the length of the box. Tilt the box 90 degrees on its side during transport. For installation, open the entire box and lift pieces rather than slide them to prevent scratching. Always keep siding material dry and protected. See Warranty card for more care and maintenance instructions. See page 18 for instructions on safe cutting procedures.

Inspect siding upon receipt. Damaged material should be reported as soon as possible to the place of purchase. Also inspect after the installation of the first three squares of siding. If a material defect is suspected, stop installation and report the concern to the place of purchase or contact Klauer Customer Service at (800) 896-3904.

PLANNING	4	Accessories
	5	Tools required
	6	Equipment
	7	Material estimating
	8	Nomenclature
GETTING STARTED	9	Preparation
	10	Furring and installation techniques
	12	Base chalk line
	13	Inside corner
	14	Outside corner
TRIM	15	Starter strip
	16	Window and door trim
	17	Window and door trim – Gable end trim
INSTALLATION	18	Cutting procedures
	19	Installing the siding
	22	Nailing and stapling
	23	Panels at windows and doors
	25	Fitting at gable ends
	26	Fitting under eaves
	27	Vertical siding
	29	Caulking and cleanup
SPECIAL SITUATIONS	30	Repairs and miscellaneous
FINAL TOUCHES	32	Soffit and fascia
	34	Rainware
WORKSHEET	36	Estimate worksheet

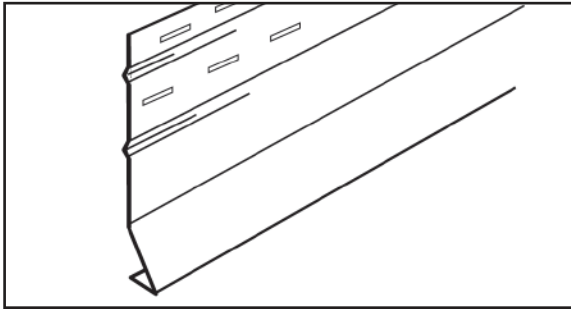

STARTER STRIP

Base-line accessory which secures the first course of siding to the wall. Used with horizontal and vertical siding. Nail 12" O.C. (on center).

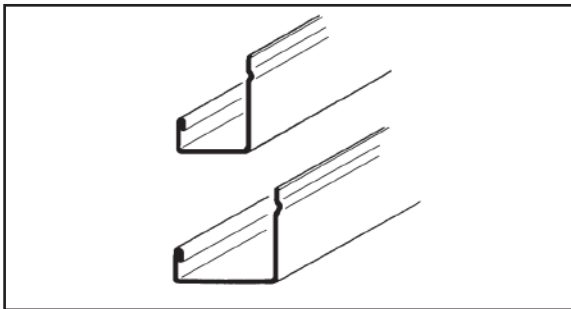

J-CHANNEL

Used for receiving siding on all sides of windows and doors, at rake edges of gables and in other miscellaneous situations. Deeper J-channels are for insulated siding, and narrower J-channels for non-insulated siding. Nailed 12" O.C.

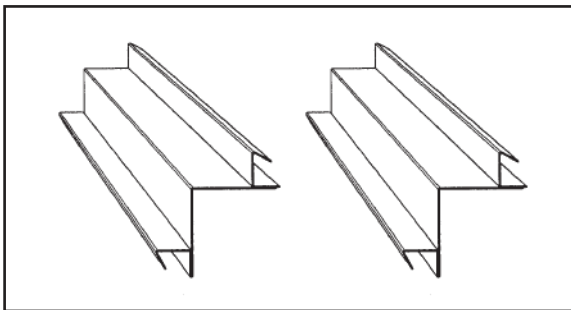

OUTSIDE CORNER BASE

Provides neat appearance outside corners for horizontal and vertical siding. Receives siding from both sides. Deeper bases are used with insulated siding, and narrower bases with non-insulated siding. Both flanges are nailed 12" O.C. Available in 3/4" and 1-1/8".

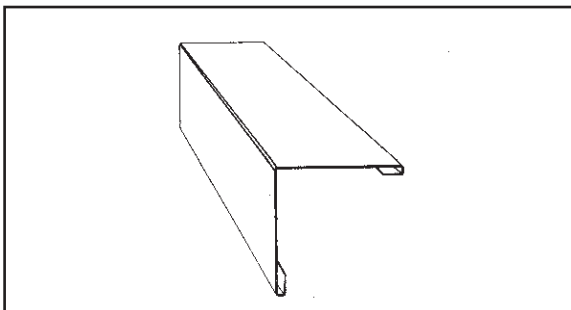

OUTSIDE CORNER CAP

Snaps in place when siding installation has been completed.

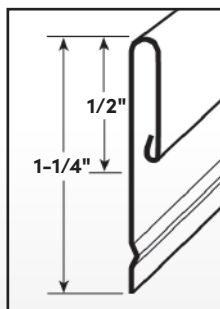

SILL TRIM

Used to finish off ("trim") jobsite cuts on siding, as under windows, at eaves, and at porch door locations. May also be used to receive vertical siding at corners and window jambs. The snap-lock design allows siding to be notched and locked into place without face nailing.

TOOLS REQUIRED

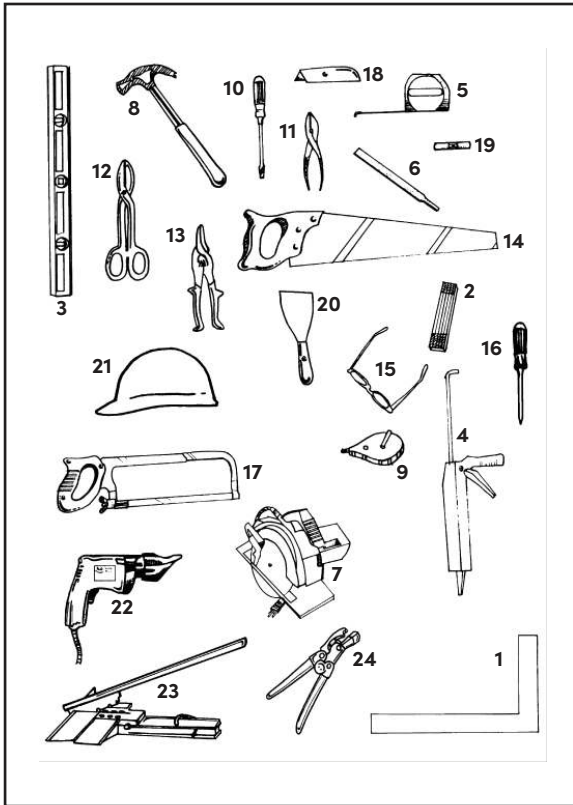

The siding applicator's job can be made much easier with the proper tools.

ESSENTIAL TOOLS

1. Carpenter's Metal Square
2. Carpenter's Folding Rule
3. 2' Level (minimum)
4. Caulking Gun
5. Steel Measuring Tape
6. Fine-Tooth File
7. Power Saw (preferably metal-cutting saw)*
8. Claw Hammer
9. Chalk Line
10. Screwdriver(s)
11. Pliers
12. Tin Snips | Duckbill-Type
13. Aviation Shears | Double-Acting
14. Carpenter's Saw | Crosscut
15. Safety Goggles
16. Steel Awl
17. Metal-Cutting Hacksaw (fine-tooth w/ 24 teeth per inch)
18. Utility Knife
19. Line Level
20. Putty Knife | 3"
21. Hard Hat
22. Electric Nibbler (optional)
23. Siding Cutter (optional)
24. Snap-Lock Punch Tool

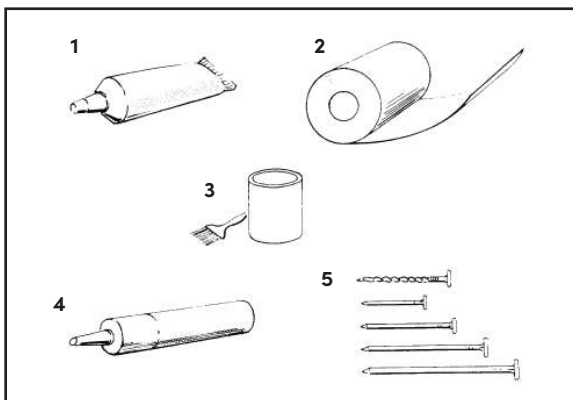

ADDITIONAL MATERIALS REQUIRED:

1. Gutter Seal
2. Trim Sheet | Available in 24" Width
3. Touch-Up Paint (colors to match siding – for vents, kitchen fans, service cables, etc.)
4. Caulking (preferably volatile organic compound [VOC] compliant)
5. Hot-Dipped Galvanized Steel Nails: 1-1/2" for general use, 2" for residing, 2-1/2" (or more) through insulated siding into soft sheathing, and 1" to 1-1/2" trim nails (colored to match siding)

NOTE:

A minimum penetration of 3/4", excluding point of nail, into solid lumber is required for nailing to be effective with plain shank nails. Ring or screw shank nails could be used through 1/2" plywood for similar effectiveness.

*For steel: A power saw can be used on steel if equipped with an approved titanium carbide-tip blade. Consult siding manufacturer.

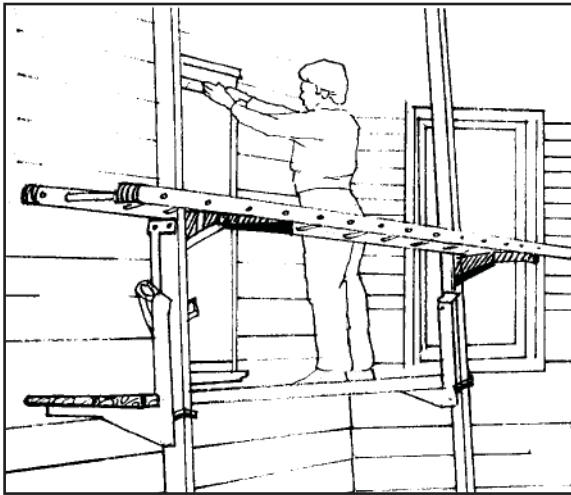

LADDERS AND SCAFFOLDS

Proper ladders and scaffolds are necessary. A pump jack is widely used to provide a working platform. The posts upon which the pump jack moves are normally two 2-by-4s nailed together to form a 4-by-4 post.

With a pump-jack platform, the distance from the building facade remains the same from the bottom to the top. Exact specifications on spacing dimensions, planking, permissible heights and loads, etc. are contained in the OSHA Construction Safety and Health Regulations under section 1926.450 and 1926.451 covering ladders and pump jacks. Contact your local OSHA office.

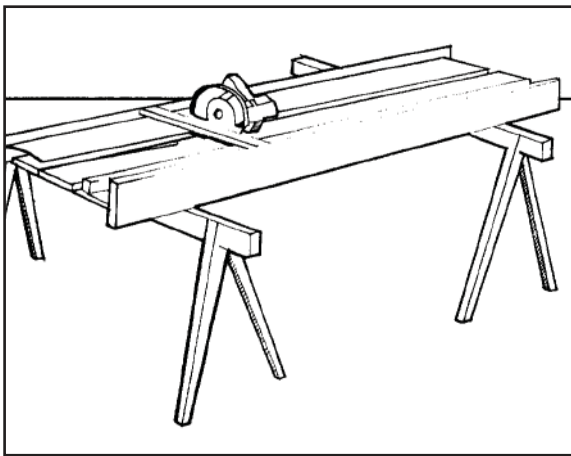

CUTTING TABLE

For a more efficient and professional operation, specialized equipment may be needed. A valuable timesaver is the portable cutoff or trim table, which allows a standard portable circular power saw to be mounted in a carrier and set aside to avoid damaging the siding. These tools can help measure and crosscut, as well as make miter and bevel cuts for siding, soffit and trim. The units are constructed of lightweight aluminum and can be easily set up on the jobsite by one person.

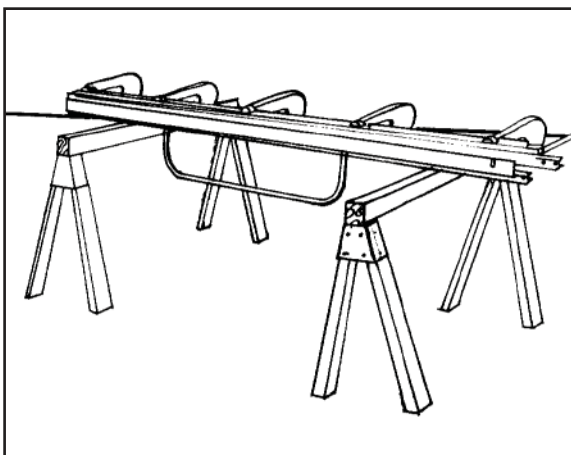

PORTABLE BRAKE

For jobsite bending of custom-trim sections, such as fascia and sill trim and window casing, a portable metal-bending machine (brake) is extremely useful. Utilizing white- or colored-coil stock, precise multiple bends can be accomplished. These machines are lightweight for easy transport to the jobsite and setup in place. Various sizes and brake styles are available.

MATERIAL ESTIMATING

SIDING

In order to determine the amount of siding needed to cover a house, the measuring process can be reduced to simple steps. Virtually all houses contain a series of rectangles or triangles, or a combination of both, regardless of how divided the face of a wall is by windows and doors (Fig. 1). Using the Fig. 2 formula below, measure the height (excluding gables) and width of each side of the house (including windows), and arrive at the area in square feet. Now compute the gable triangle areas using the Fig. 3 formula below and total them. Window and door areas are generally not deducted, as figuring them in the wall area will allow for waste. If window and door areas are extremely large (such as garage or sliding glass doors), some deduction can be made. Dormers and gables are traditionally prone to material waste due to cutting and fitting; to compensate, add 1' in height to the original measurements. For vertical siding, allow approximately 20 percent of additional material for waste.

NOTE:

Also see siding material estimating worksheet on back cover.

ACCESSORIES

To determine the amount of starter strip required, measure the lineal feet around the entire base of the building to be covered. For corner posts and accessories, also measure in lineal footage and add a factor of approximately 10 percent to allow for waste.

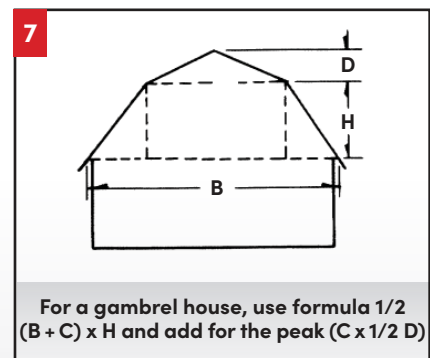
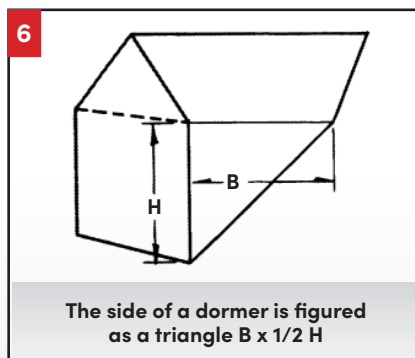
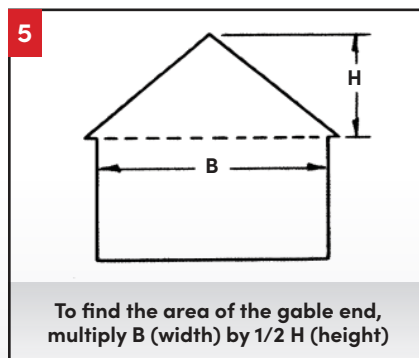
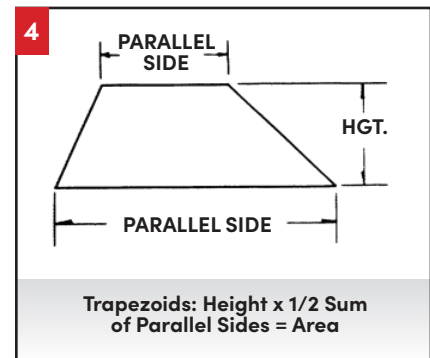
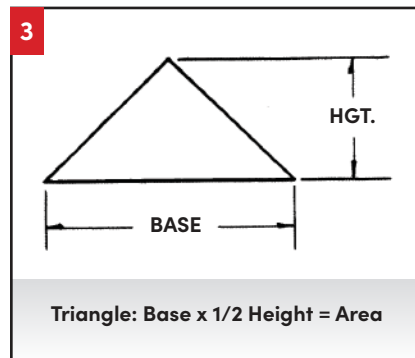
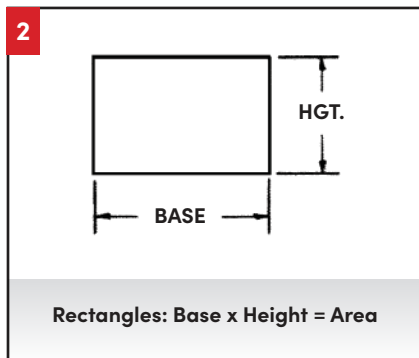
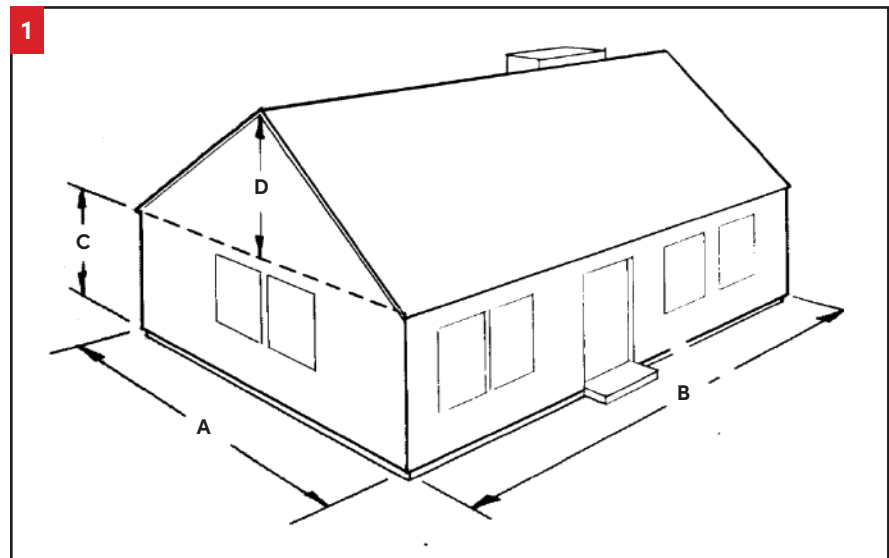

NOMENCLATURE

References will be made throughout this manual to various parts and pieces associated with house construction. The drawing below identifies the most common descriptive terms and shows their location on a typical house.

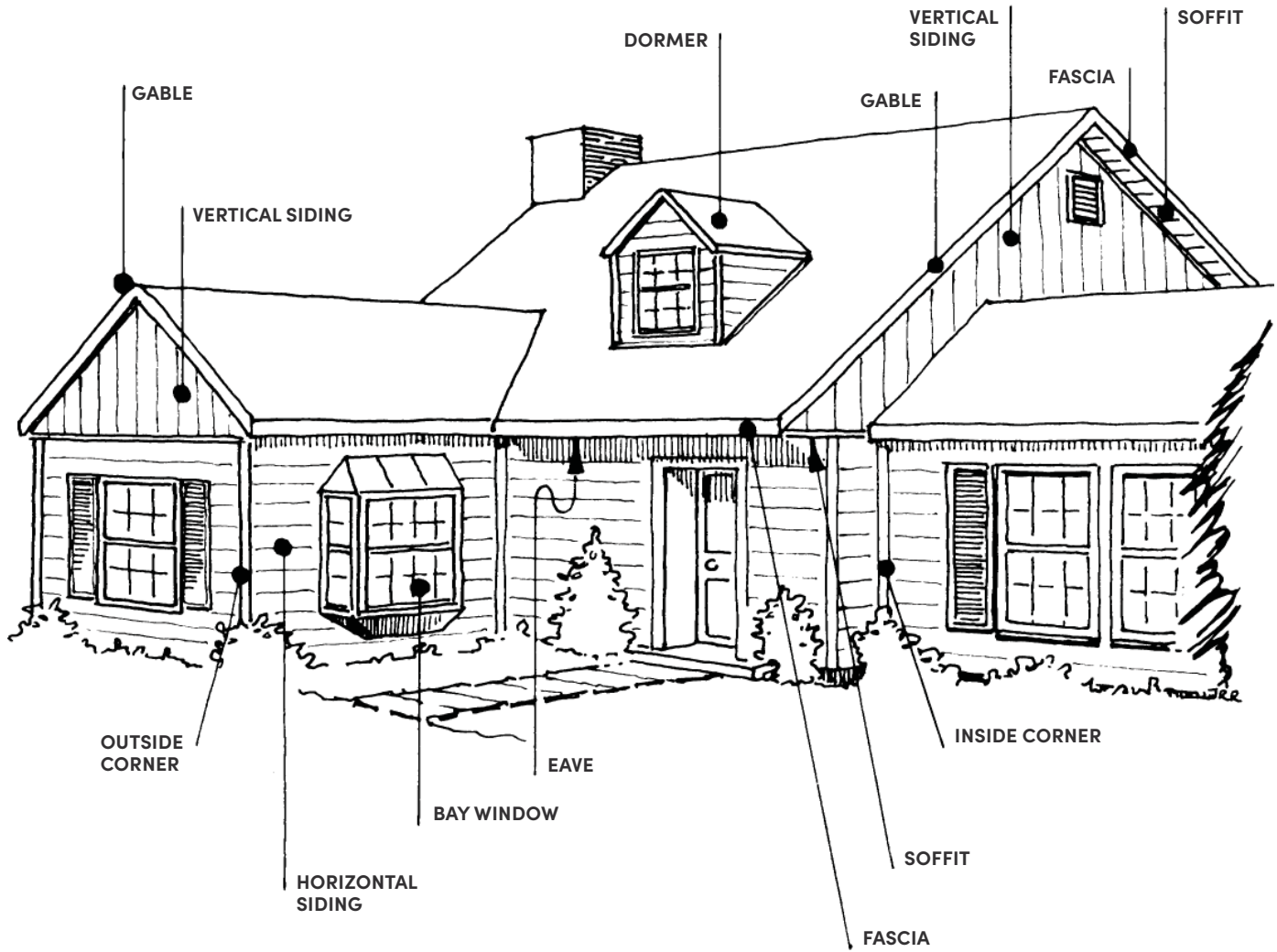



SURFACE PREPARATION

The quality of the finished job depends on the proper preparation of the work surface. Check for low places in the plane of the wall and build (shim) out if required. Prepare the entire building a few courses at a time. Securely nail all loose boards and wood trim. Replace any rotted boards. Scrape away old paint buildup, caulking and hardened putty, especially around windows and doors where it might interfere with the positioning of new trim. New caulk should be applied to prevent air and water infiltration.

NOTE:

Uneven and/or out-of-plumb surfaces can create waves or oil-canning as well as irregular shadow patterns in siding panels.

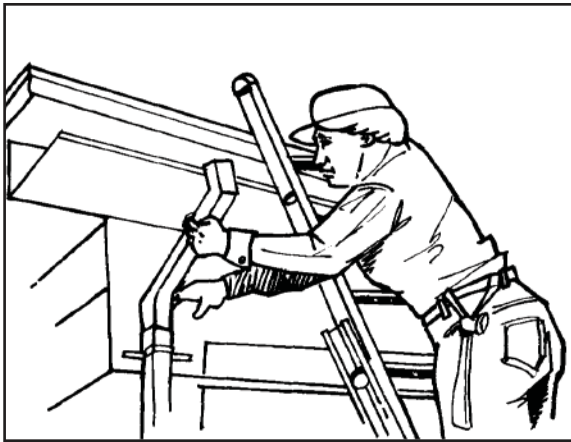

REMOVE DOWNSPOUTS / TIE BACK SHRUBS

Remove downspouts and other items that would interfere with installation of new siding. Tie back shrubbery and trees from the base of the building to avoid damage to the landscaping.

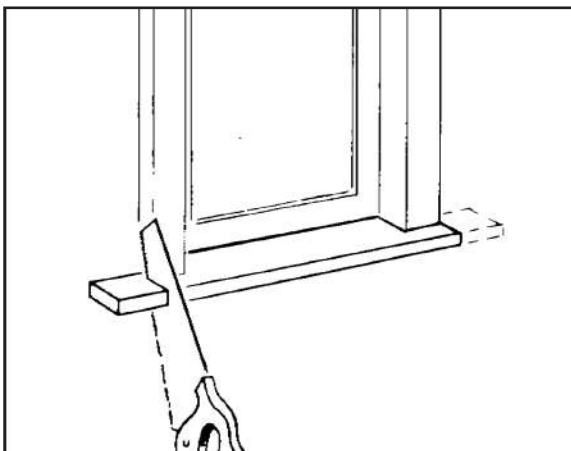

WINDOWSILL PREPARATION

Windowsill extensions may be cut off so J-channel trim can be installed flush with window casings.

To maintain the original window design, coil stock can be custom-formed around the sill instead of cutting away the extensions.

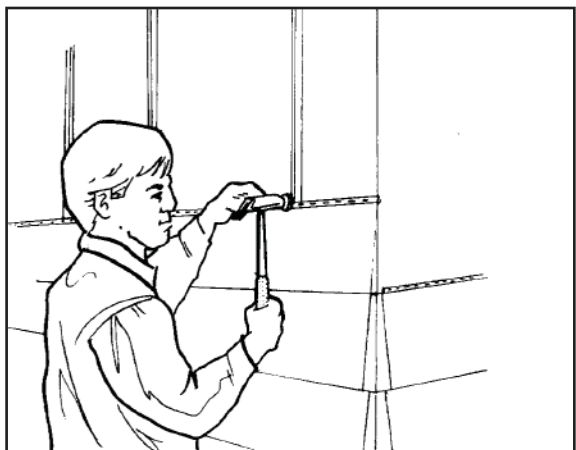

WOOD FURRING

Furring is the process of building out from the wall surface to provide a smooth, even base for nailing on the new siding. Lath strips $\frac{3}{8}$ " thick are most commonly used. Lumber strips measuring 1" x 3" are often used over brick and masonry. Furring is not usually necessary in new construction, but older homes often have uneven walls, and furring out, or shimming, low spots can help prevent a wavy appearance to the installed siding. Insulation value can be added by furring out an entire wall (see page 13). Furring should be installed 16" vertically on center for horizontal siding, and the air space at the base of the siding should be closed off with strips applied horizontally. Window, door, gable and eave trim may have to be built out to match the thickness of the wall furring.

VERTICAL SIDING

Furring for vertical siding is essentially the same as for horizontal siding, except the wood strips are securely nailed horizontally into structural lumber on 16" to 24" centers. When using 1" x 3" furring, be sure to check what effect the additional thickness might have on the trim.

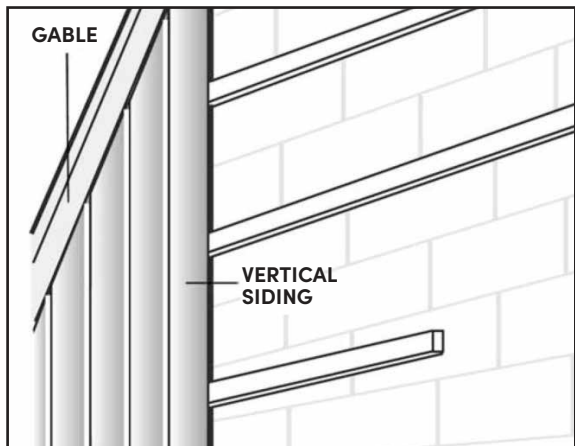

UNDERLAYMENT

Fanfold $\frac{1}{4}$ – $\frac{3}{8}$ " thick
Housewrap

Siding is to be installed directly over properly installed underlayment. We specify that an underlayment be used on all applications prior to the installation of the siding. We also recommend the following:

- a. All seams and channeling are to be taped to help prevent air and water infiltration.
- b. All outside and inside corners should be wrapped continuously.
- c. Underlayment is to be installed over roof or brick flashing, and then taped to help prevent water and air infiltration.
- d. Underlayment is to cover from the top to the bottom of the wall including all gables.
- e. When using housewrap, seams are to be overlapped a minimum of 1' and then taped.
- f. Use plastic-cap fasteners to attach the fanfold underlayment to the wall.
- g. Prior to the installation of siding on a retro project, the fanfold must be applied over the top of the existing siding so there is a flat surface to apply the new siding onto.
- h. The fanfold is applied with the foil facing inward.

NOTE:

Whenever installing any type of insulation or housewrap products, follow the manufacturer's installation instructions.

Klauer Manufacturing Company does not recommend installing drop-in foam backer for any of its manufactured siding panels.



WINDOW AND DOOR BUILD-OUT

Some trim build-out may be required at windows and doors to maintain the original appearance of the house when using furring strips or underlayment board, particularly if it is more than 1/2" thick. Thicker furring and underlayment generally provide added insulation value and are usually a good investment for the homeowner, particularly if the home is non-insulated. When estimating the labor and materials required for installing furring and underlayment, be sure to include window and door build-out. Longer siding nails will be needed to compensate for the added thickness of the insulation board.

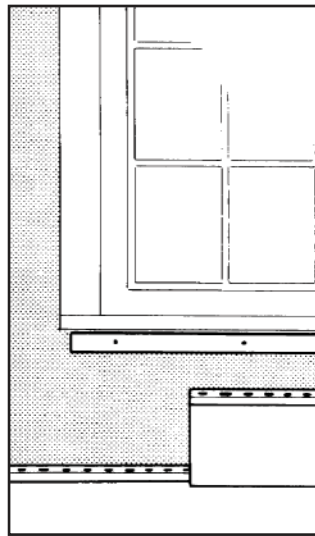

UNDERSILL FURRING

Building out below window sills is often required in order to maintain the correct slope angle if a siding panel needs to be cut less than full height. The exact thickness required will be apparent when the siding courses have progressed up the wall and reached this point (see page 23).

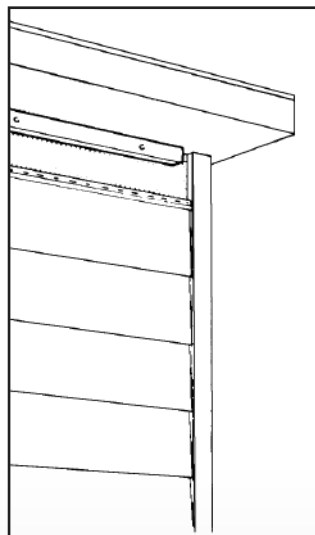

UNDEREAVE FURRING

For the same reason, furring is usually required to maintain the correct slope angle of the last panel where it terminates at the eave. This panel usually has to be cut to less than full height, thus requiring backup furring and a special piece of trim for capping (see page 26).

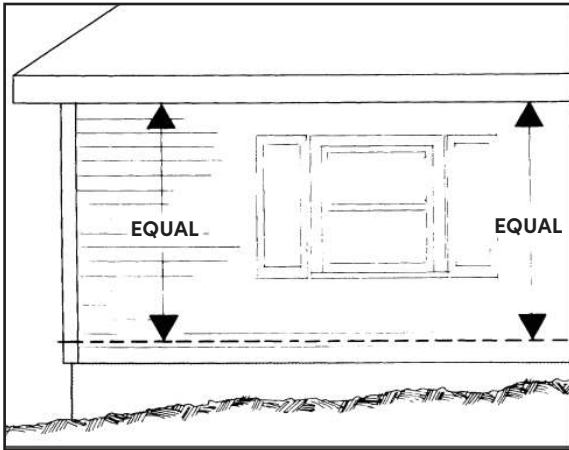

STRAIGHT LINE

The suggested procedure is to measure equal distances downward from the eaves and/or windows. This ensures that the siding appears parallel with the eaves, soffit and windows, regardless of any actual settling of the house from true level.

NOTE:

The key element in a successful siding installation is establishing a straight reference line upon which to start the first course of siding.

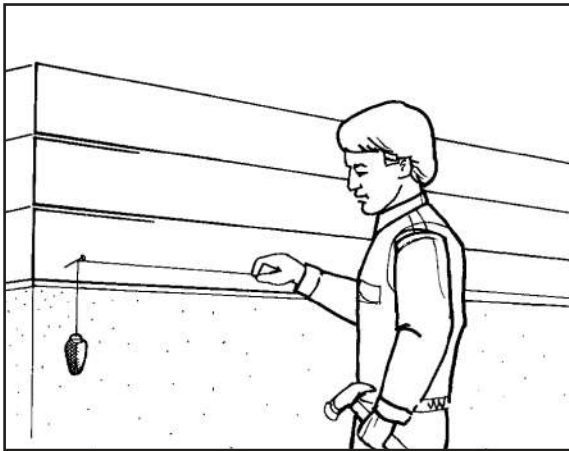

CHALK LINES

Find the lowest corner of the house and drive a nail about 10" above it, or enough to clear the height of a full siding panel. Stretch a taut chalk line from this corner to a similar nail installed at another corner. Reset this line based upon measurements from points of equal dimension down from eaves or windows. Repeat this procedure on all sides of the house until the chalk lines meet at all corners. Before snapping chalk lines, check for straightness. Be alert to sag in the middle, particularly if the line is more than 20' long. If preferred, lines may be left in place while installing the starter strip, as long as they are checked periodically for excess sag.

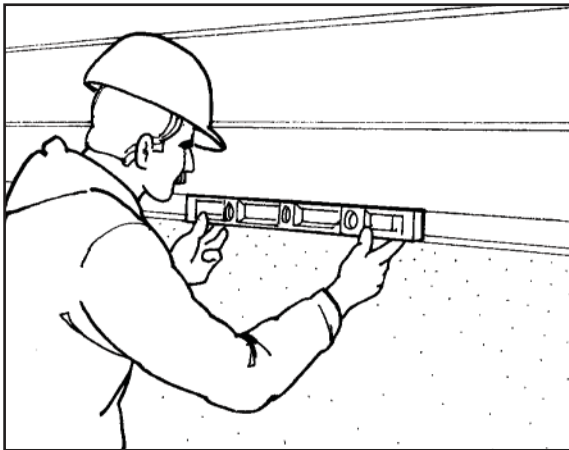

LEVEL

If the house is reasonably level, an alternative is to use a level to set the chalk line approximately 2" (or the width of the starter strip) from the lowest point of the old siding, and locate the top of the starter strip to that line. Be careful when using a standard carpenter's level because progressive measurements may increase the possibility of error. The level should be at least 2' long, and preferably longer. Take a level reading at the center of the chalk line for best results.

INSIDE CORNER

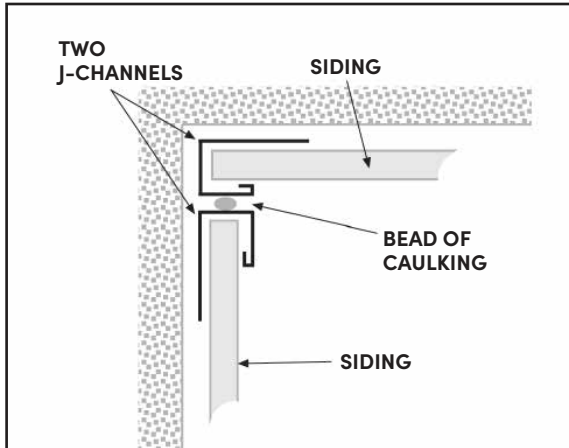

INSTALLATION

Two J-channels at right angles may also be used as an inside corner. A bead of caulking will assist in preventing water penetration at the junction. Deeper or narrower J-channel may be required, depending on the type of siding (insulated or non-insulated). Set the J-channel full length in the corner, reaching from 1/4" below the bottom of the starter strip up to the eave or gable trim. Nail approximately every 12" on both flanges. Make sure the J-channel is set straight and true. Flanges should be nailed securely to the adjoining wall, but do not overdrive nails so as to cause distortion.

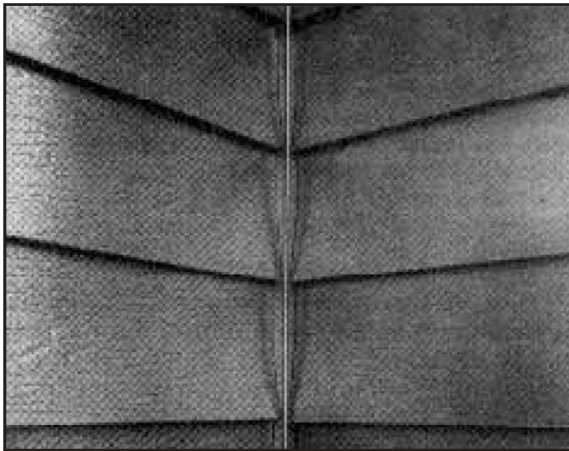

EXPANSION ALLOWANCE

Butt the siding into the corner and nail it into place to allow approximately 1/16" space between the J-channel and the siding for expansion purposes. (See page 20 for more information on expansion and contraction requirements.)

OUTSIDE CORNER

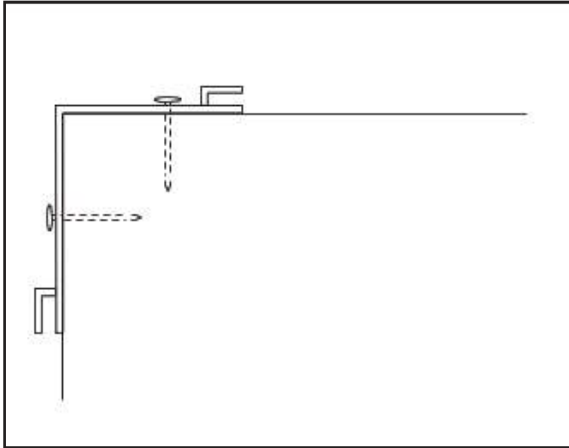

BASE

Nail every 12" in nail slots on both sides of the corner base. Make sure both sides are securely nailed, but avoid the distortion caused by overdriving nails. If insulation is being used, wide bases may be needed. The base should extend 1/4" below the starter strip.

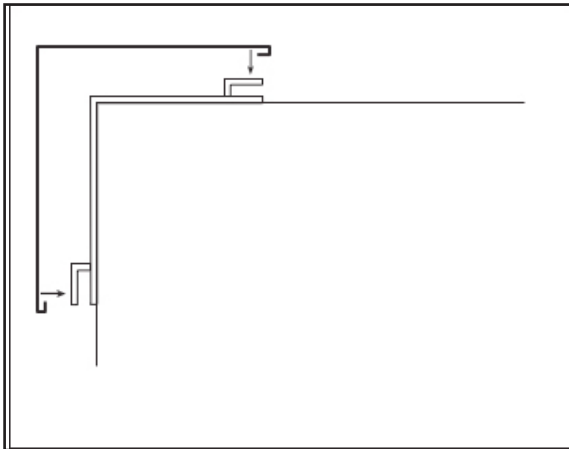

CAP

The outside corner post produces a trim appearance. Set a full-length piece over the corner base running from 1/4" below the bottom of the starter strip to the underside of the eave. If a longer corner cap is needed, overlap corner post sections with the upper piece outside.

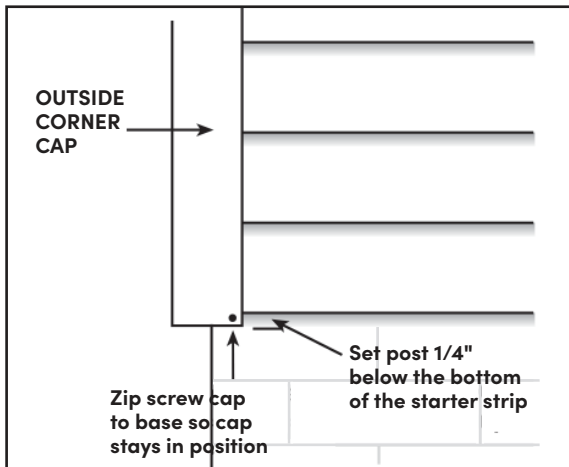

INSTALLATION

The outside corner post produces a trim appearance and will accommodate the greatest variety of siding types.

Set a full-length piece over the outside corner base running from 1/4" below the bottom of the starter strip to the underside of the eave. Fix the cap to the base with a screw. If a longer corner post is needed, overlap corner post sections with the upper piece outside.

STARTER STRIP

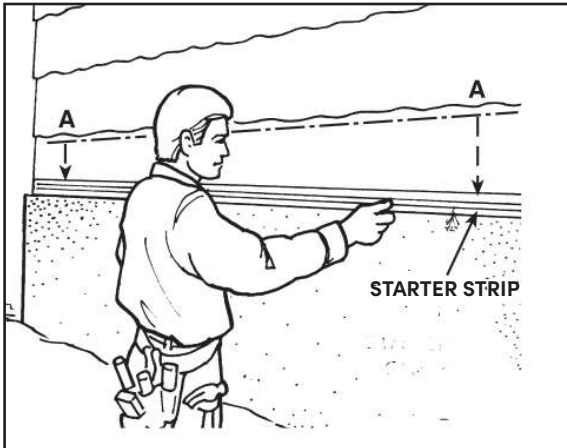

HORIZONTAL SIDING

Using the chalk line previously established as a guide, take measurements at equal distances (see "A" in diagram) and install starter strip all the way around the bottom of the building. If insulated siding is used, the starter strip should be furred out the thickness of the backer (see page 28). It is extremely important that the starter strip be straight and meets accurately at all corners as it will determine the line of all installed siding panels. Where hollows occur in the original wall surface, shim out behind the starter strip to prevent a wavy appearance of the finished siding.

VERTICAL SIDING

A plumb line should be used when applying starter strip in a vertical position (see page 27).

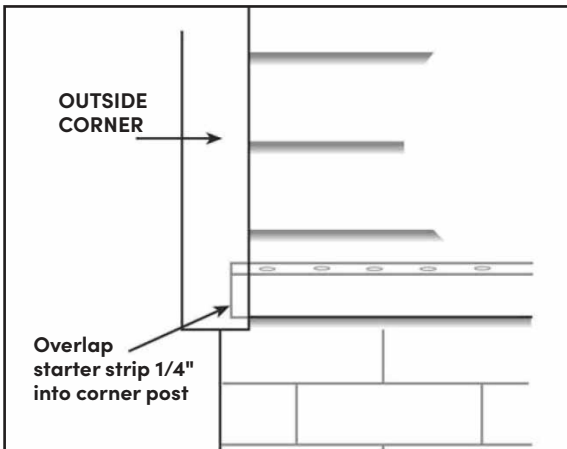

NAILING

The starter strip should overlap the corner-base flanges to help reduce air and water infiltration. Space nails not more than 8" apart to securely fasten the starter strip. Nail the starter strip as low as possible, being careful not to bend or distort it. Do not overdrive nails. Cutting lengths of starter strip is best accomplished with tin snips. Butt sections together.

ALTERNATIVES

Starter strip may not work in all situations. J-channels or sill trim may work better in starting siding courses over garage doors and porches or above brick, for example. Situations must be handled on an individual basis as they occur (see page 31).

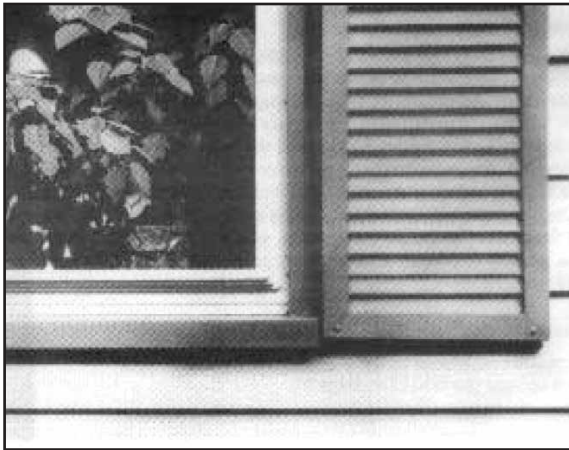

COIL STOCK

For a superior remodeling job and freedom from maintenance, the original window sills and casings can be covered with aluminum- or steel-coil stock bent to fit on the jobsite.

Sometimes window and door casings need to be built out to retain or improve the original appearance of the house. To do this, nail appropriate lengths and thicknesses of good-quality lumber securely to existing window casings. Remove storm windows before covering casings with coil-stock sections custom-formed on the jobsite.

Forming coil sections to fit window and door casings is done with a portable brake as follows:

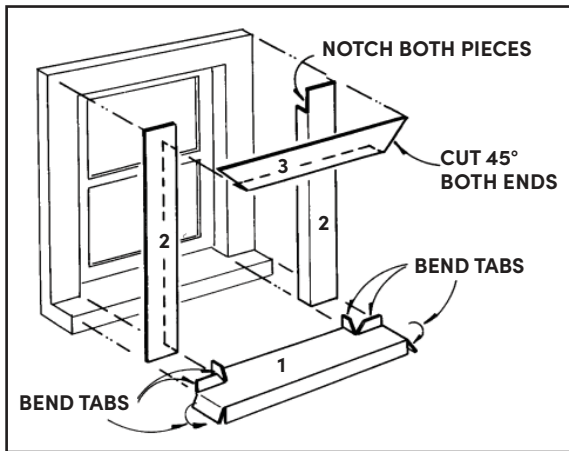

1. Sill Cover – Form trim to the dimensions of the wood sill being covered. For flashing purposes, snip and fold the upright tabs at the jamb locations and sill ends as shown. Install with small-head trim nails and/or adhesive.
2. Casing Cover – Form casing trim to the dimensions of the wood jamb being covered. Install over the vertical flashing tabs of the sill-cover trim. Fasten in place same as above.
3. Window-Head Cover – Form to the dimensions of the wood head being covered. Miter corners on both sides as shown. Install so as to lap over the casing-trim pieces and fasten in place.
4. Caulk – Apply where necessary to prevent water penetration behind the trim pieces.

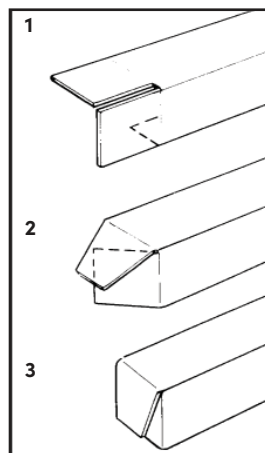
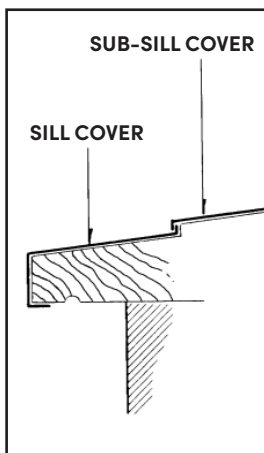

TWO-PIECE SILL

If there is a step in the wood sill, it can best be covered by bending two separate sill-cover pieces as shown. Let the flanges lap over for best water runoff.

SILL ENDS

By using tin snips and bending flanges, the old sill ends can be boxed-in to provide a neat appearance and prevent water penetration.

NOTE:

Care must be exercised in placing aluminum or steel in contact with materials such as dissimilar metals, concrete, stucco, asbestos siding, pressure/pre-treated lumber, masonry or corrosive nonmetallic materials that might become repeatedly wet.

WINDOW AND DOOR TRIM – GABLE END TRIM

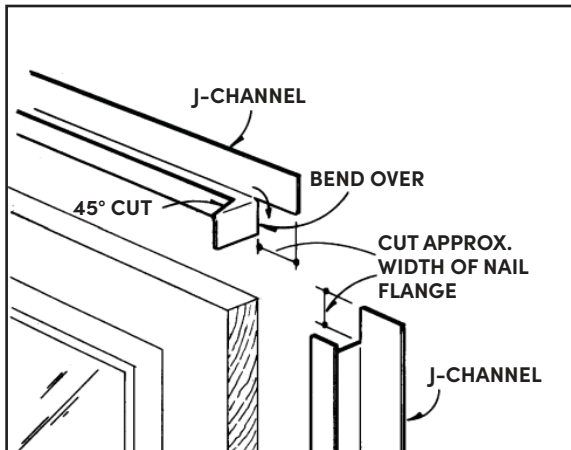

TRIM

J-channel is used around windows and doors to receive siding. Side J-channel members are cut longer than the height of the window or door and notched at the top as shown. Notch the top J-channel member at a 45° angle and bend the tab down to provide flashing over side members. Caulking may be used behind J-channel members to prevent water infiltration between the window and the channel. Do not caulk the siding inside of the J-channel to attempt to seal it.

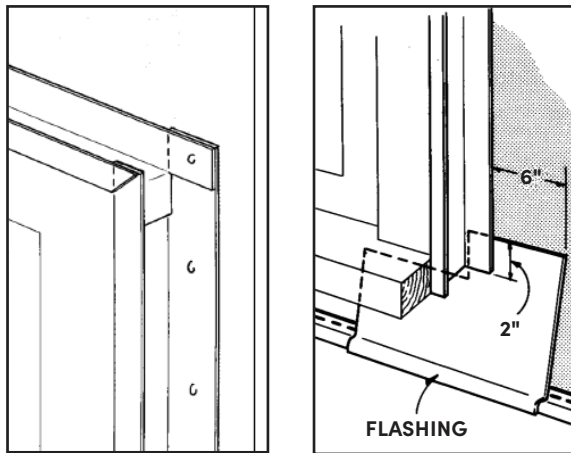

FLASHING

To prevent water from getting behind the siding, a flashing piece may be cut from coil stock, slipped under the base of the side J-channel members and positioned so as to lap over the top lock of the panel below (see illustration).

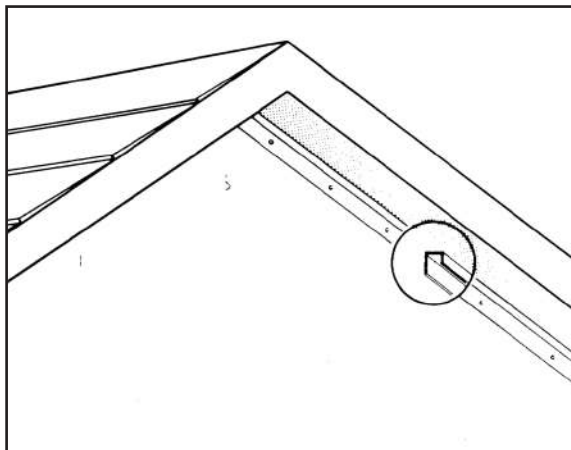

GABLE ENDS

Before applying siding, J-channel should be installed to receive siding at the gable ends. Where the left and right sections meet at the gable peak, let one of the sections butt into the peak with the other section overlapping. A miter cut should be made on the face flange of this piece to improve its appearance. All old paint buildup should be removed before installing J-channels. Nail every 12" to 16".

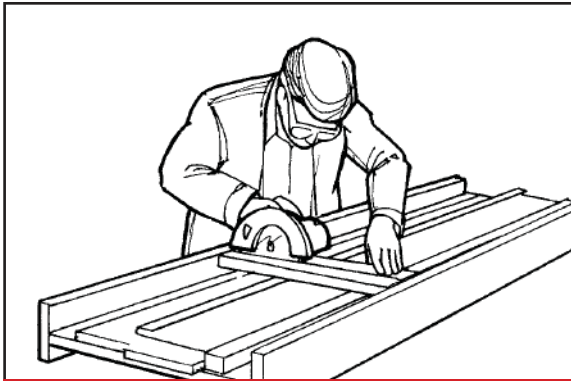

CAUTION: Safety glasses should be worn at all times while operating a power saw.

POWER SAW | STEEL

Typically, steel should not be cut using any heat-generating device such as an electric circular saw or jigsaw – to do so may destroy the protective galvanized coating and damage the siding. However, a power saw (preferably metal) can be used on steel if it is equipped with an approved titanium carbide-tipped saw blade.

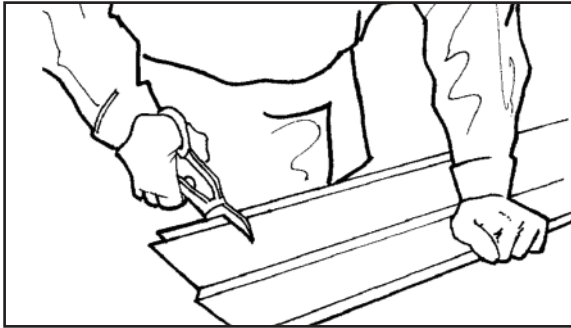

TIN SNIPS | STEEL

Individual panels can be cut with tin snips. Start by drawing a line across the panel using a square. Begin cutting at the top lock first and continue toward the bottom of the panel. Break the panel across the butt edge and snip through the bottom lock. Use a screwdriver to reopen the lock, which may become flattened by tin snips (see drawing). Aviation shears are sometimes used to cut the top and bottom locks, and a utility knife can score and break the face of the panel. For straight cuts, the best choice is duckbill snips.

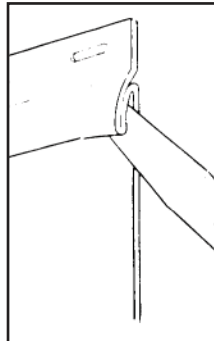
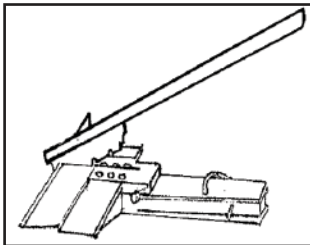

SIDING CUTTER | STEEL

Using a guillotine-type cutting device designed to cut at vertical right angles to siding is the **preferred method** for making straight cuts without damaging galvanized coating. Interchangeable blades for cutting 4", 5" and 8" profiles are available. See your dealer for more information.

NIBBLER | STEEL

An electric punch-action cutter is best for making straight, curved or circular cuts.

INSTALLING THE SIDING

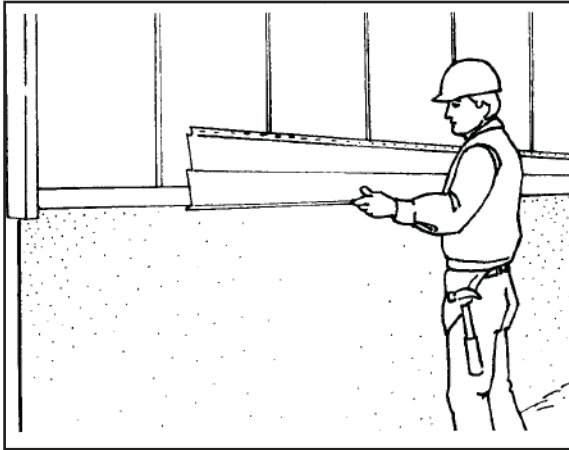

FIRST COURSE

Extra care must be taken when applying the first course of siding because it establishes the base for all other courses. Apply the panel by hooking the bottom lock into the interlock bead of the starter strip, making sure the lock is engaged. Do not force or jam it, which might cause distortion of the panel and result in an undesirable shadow line. Double-check for continuous locking along the panel and for alignment at the corners before proceeding. The first course should be installed a minimum of 6" from the ground.

At the corner bases, first slide the panel into the recess, then exert upward pressure to lock the panel into place along its entire length. Allow clearance for expansion as necessary (see page 20). Panels must be hung with nails through the center of the factory-slotted holes every 16" to 24" along the entire length. Nails must be driven into sound lumber, such as 3/4" penetration into house framing with plain shank nails or through 1/2" plywood with screw or ring shank nails.

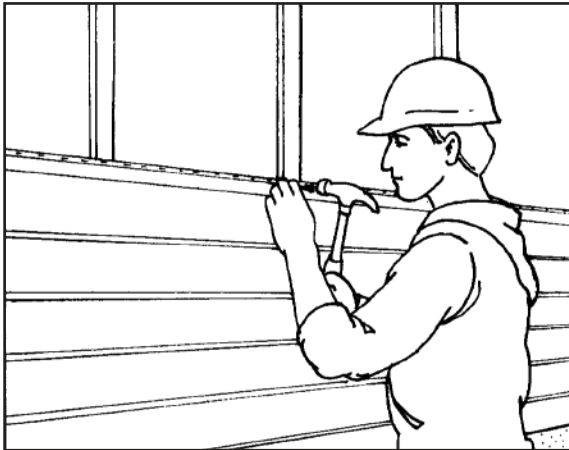

INSTALLING THE SIDING

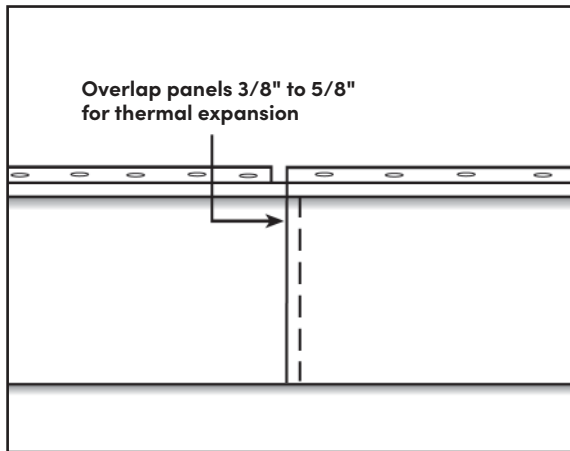
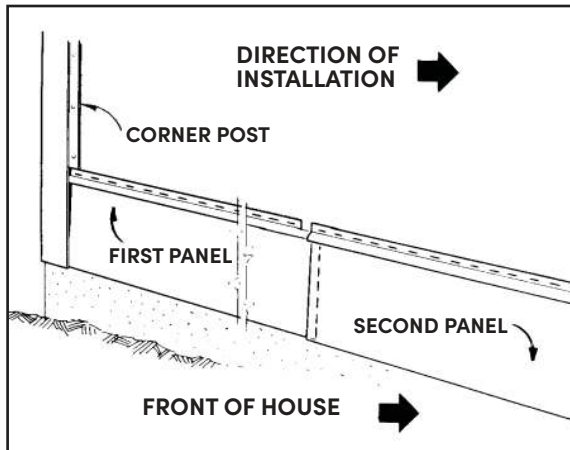

LAPPING

On the sides of the building, start at the rear corner and work toward the front, so that lapping will be away from the front and less noticeable. On the front of the building, start at the corners and work toward the entrance door for the same reason. When lapping, the factory-cut ends of panels should be on top of field-cut ends for the best appearance.

OVERLAPPING

Panels should overlap each other by approximately 1/2". A maximum of 5/8" and a minimum of 3/8" is a good rule of thumb. Thermal expansion requirements need to be considered when overlapping panels (see below).

1. Avoid short panel lengths of less than 24".
2. Make sure factory-cut ends are always on top of field-cut ends.
3. Start at the rear of the house and work toward the front.

EXPANSION AND CONTRACTION

Allowance for expansion or contraction should be made when installing siding. Metal siding will expand when heated and contract when cooled. Expansion can amount to approximately 1/8" in a 10' length for every 100° of temperature change.

If siding is installed in hot weather, the product is already warm and at least partly "expanded," therefore less room will be required to allow for temperature expansion. If the product was stored in a hot or direct-sun area, the applicator should apply the siding panel against a corner base with a minimum clearance of 1/16". In cold weather, assuming the product was stored outside, the applicator should allow approximately 1/8" of space between areas of possible restriction, such as at a corner base.

Using this expansion and contraction "common sense," the applicator should be able to properly install products for the best appearance, and thus avoid the unnecessary waves or buckles that could occur with temperature changes.

INSTALLING THE SIDING

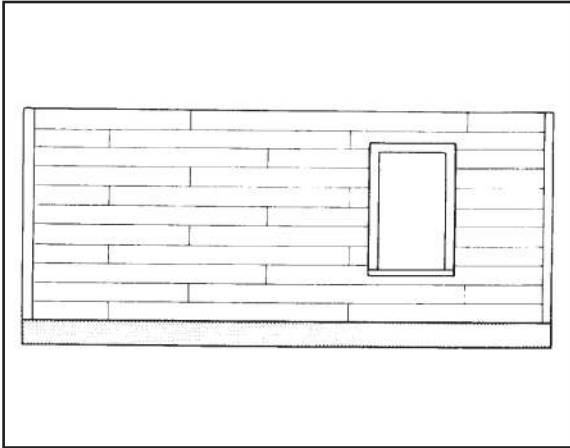

PROPER STAGGERING OF PANELS

For the best appearance, the staggering of joints should be well planned. Many applicators plan joining so that any two joints in a vertical line will be separated by at least two courses (see illustration). At a bare minimum, separate panel overlaps on the next course by at least 2". Joints should be avoided on panels directly above and below windows. Shorter pieces that result as work proceeds can be used for smaller areas around windows and doors.

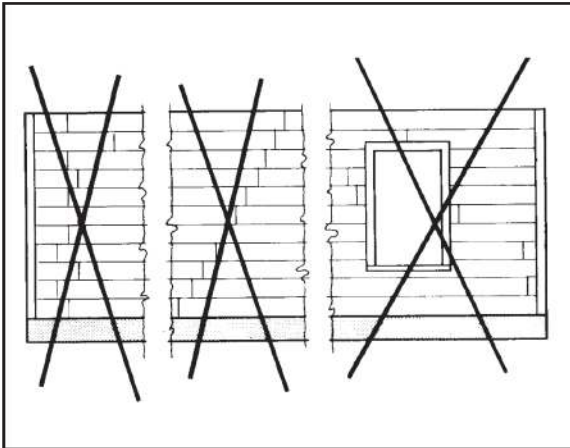

IMPROPER STAGGERING OF PANELS

A poor arrangement of panel overlaps detracts from the appearance of the installation (see illustration).

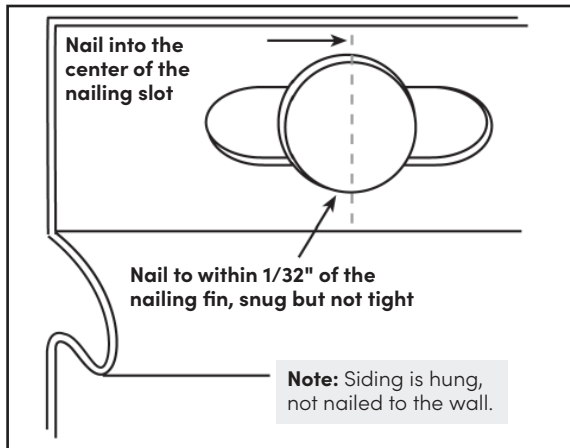

HANGING THE SIDING

Drive the nail snugly but not tightly through the center of the factory-slotted hole to within 1/32" of the nailing flange. The slots are elongated to permit the siding to contract and expand freely. Siding nailed too tightly may not be able to move with temperature changes, resulting in an unattractive wavy appearance. Expansion requirements vary seasonally. An application installed in the hot summer requires less allowance. An application installed in winter may require an expansion allowance of as much as 1/8" per panel (see page 20).

NOTE:

Uneven and/or out-of-plumb surfaces can create waves or oil-canning in siding panels as well as irregular shadow patterns.

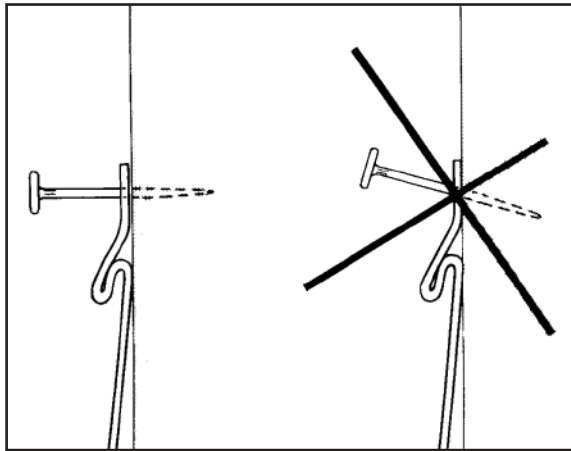

NAILS

When nailing siding and accessories, always use the correct size nails. Nails should be driven straight and level, never slanted up or down so as to possibly cause distortion of the panel. Use 2" or longer nails for insulated siding and 1-1/2" or longer nails for non-insulated siding as well as most trim accessories. A minimum penetration of 3/4" into studs with plain shank nails or through 1/2" plywood with screw shank nails is recommended. Where visible nails are required, use trim nails that match the siding or accessory.

NAILING CENTERS

Siding nails should be spaced approximately 16" O.C., for a maximum of 24", and not closer than 6" from panel overlaps. Where low spots are encountered in a wall, drive the nails on both sides of the low spot and allow the panel to float over it to maintain a straight shadow line. On new construction, nail into the studs 16" O.C. Do not skip studs. In remodeling, when siding is installed over old wood, be sure that rotted or broken boards are not used as the nailing base.



PNEUMATIC STAPLERS/NAILERS

Power fasteners are an accepted alternate method for installing siding. The same care must be taken as when nailing by hand. Drive the fastener snugly but not tightly through the center of the factory-slotted hole to within 1/32" of the nailing flange. Fasteners must be corrosive resistant, such as cadmium-coated or galvanized steel, and must be long enough to penetrate at least 3/4" into a solid substrate. The staple crown should be a minimum width of 3/8". Check the gun, air pressure and your technique on the first course, and make any necessary adjustments. Always follow the pneumatic power fastener manufacturer's instructions for safe and proper use of the power gun.

PANELS AT WINDOWS AND DOORS

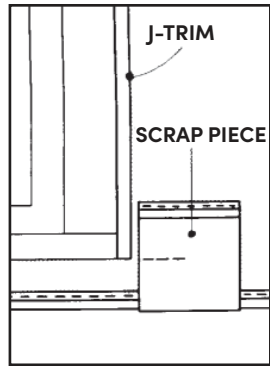

MEASURING

As siding courses reach a window, a narrower panel will probably need to be cut to fit the space under the window opening so the panel will extend on both sides of the opening. Hold the panel in place to mark for the vertical cuts. Use a small piece of scrap siding as a template, placing it next to the window and locking it into the panel below. Make a mark on this piece 1/4" below the sill height to allow clearance for the sill trim. Do the same on the other side of the window, since windows are not always absolutely level.

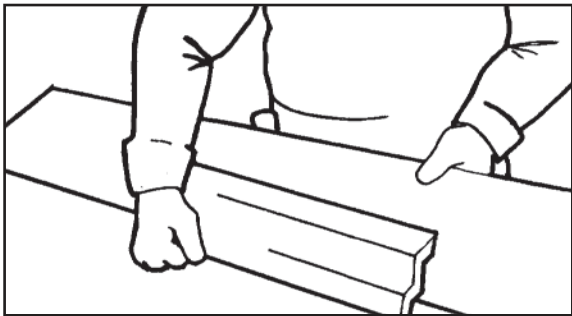

CUTTING

Vertical cuts should be made from the top edge of the panel with duckbills, tin snips or a power saw.*

*A power saw can be used on steel if it is equipped with an approved titanium carbide-tipped saw blade.

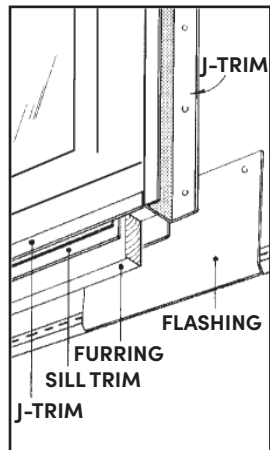

TRIMMING AND FURRING

The raw-cut edge of the panel should be trimmed with a snap-lock finish trim the exact width of the sill. First determine if furring is required behind the cut edge to maintain the slope angle with the adjacent panels. Nail the correct thickness of furring under the sill and install snap-lock finish trim over it, nailing up close under the sill for a tight fit.

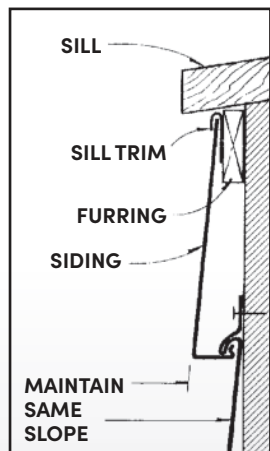

INSTALL

With a snap-lock punching tool, punch slots every 12" to 16" along the top 1/4" of the panel. Slide the panel upward so as to engage the sill trim, the J-channels on the sides of the window and the lock of the panel below.

PANELS AT WINDOWS AND DOORS

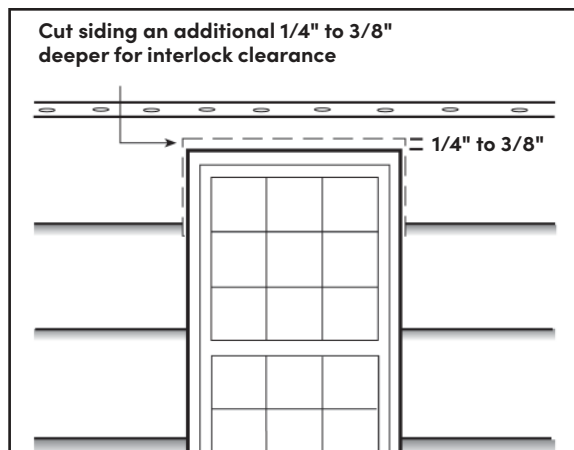

MEASURING AND CUTTING

Fitting panels over door and window openings is almost the same as making undersill cutouts, except that clearances for fitting the panel are different. The cut panel on top of the opening needs more room to move down to engage the interlock of the siding panel below on both sides of the window. Mark a template on a scrap piece without allowing clearance, and then make cuts 1/4" to 3/8" deeper than the mark to provide the necessary interlock clearance.

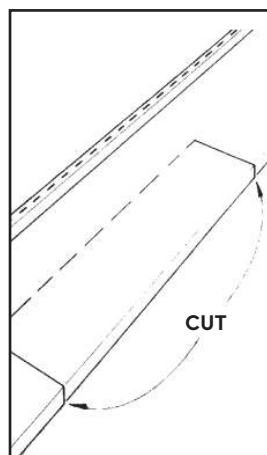
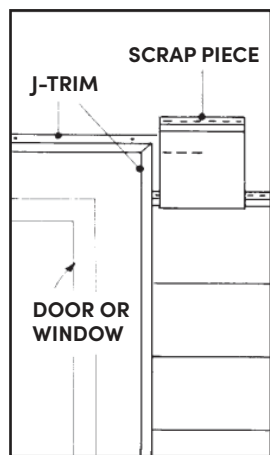

FURRING

Check the need for furring over the top of the window or door in order to maintain the slope angle, and install if required.

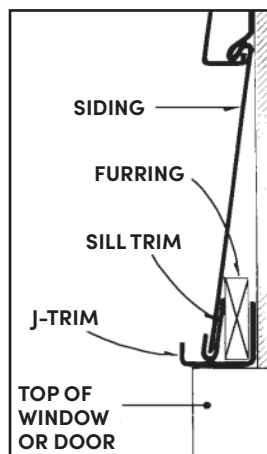
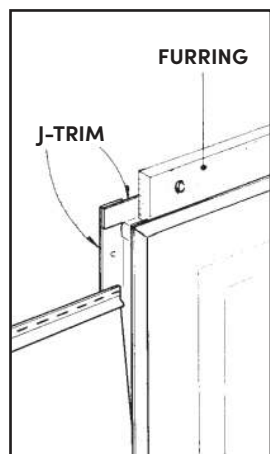

TRIM

Cut a piece of sill trim the same width as the raw edge of the cut panel, and slip it over the cut edge in the panel before installing. Drop the panel into position, engaging the interlocks on the siding panels below. The sill trim can now be pushed downward to close any noticeable gap at the juncture with the J-channel.

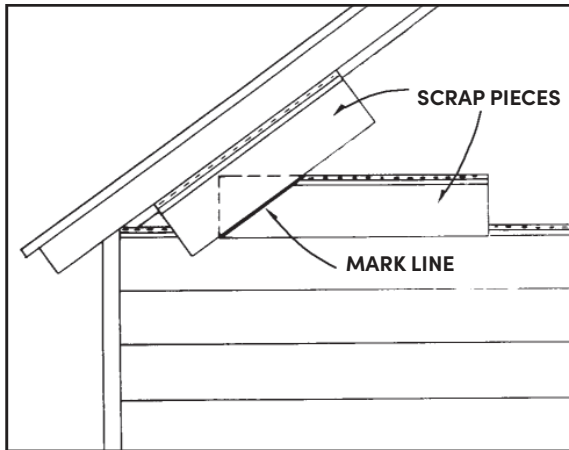

MEASURING AND CUTTING

When installing siding on gables, diagonal cuts will have to be made on some of the panels. To make a pattern for cutting panels to fit the gable slope, use two short pieces of siding as templates. Interlock one of these pieces into the panel below. Hold the second piece against the J-channel trim on the gable slope. Along the edge of this second piece, scribe a line diagonally across the interlocked panel and cut along this line with tin snips or a power saw. This cut panel is a pattern that can be used to transfer cutting marks to each successive course along the gable slope. This pattern should be checked on each course for accuracy as the slope is not always straight. All roof slopes can be handled in the same manner as gable-end slopes.

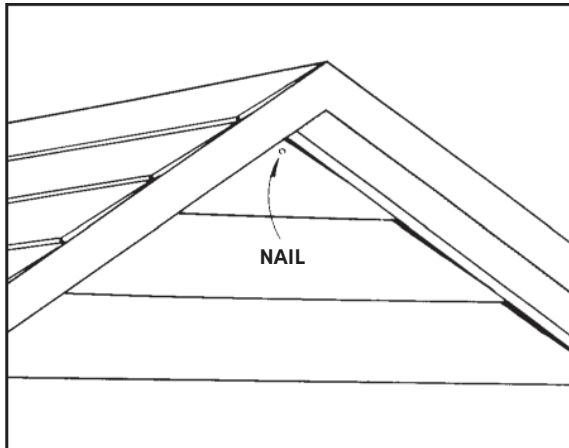

INSTALLATION

Slip the angled end of the panel into the J-channel trim previously installed along the gable edge. Lock the butt into the interlock of the panel below. Remember to allow for expansion or contraction where required. If necessary, face nail using a 1-1/4" or longer painted-head nail in the apex of the last panel at the gable peak. Touch-up enamel in matching siding colors can also be applied to exposed nailheads.

Do not cover existing louvers. Attic ventilation is necessary in summer to reduce temperatures and in winter to prevent the accumulation of moisture.

FITTING UNDER EAVES

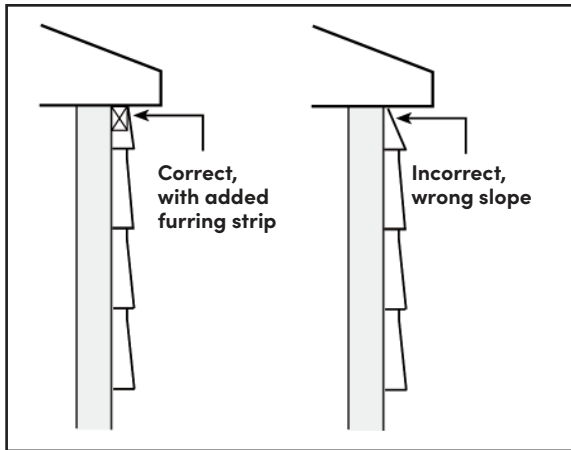

FURRING

The last panel course under the eaves will almost always have to be cut lengthwise to fit in the remaining space. Usually furring will be needed under this last panel to maintain the correct slope angle. Determine proper furring thickness and install. Nail the sill trim furring strip flush with the eave line. Trim should be cut long enough to extend the length of the wall.

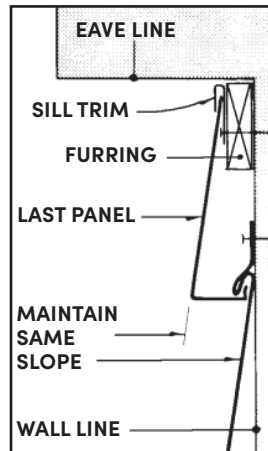
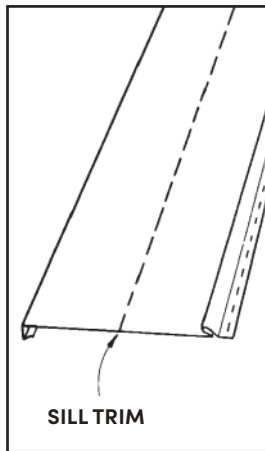

CUTTING

To determine the width of cut required, measure from the bottom of the top lock to the eaves, subtract 1/4" and mark the panel for cutting. Take measurements at several points along the eaves to ensure accuracy. With a punch tool, punch notches every 12" to 16" along the top of the panel at 1/8" to 1/4" from the edge.

INSTALLING

Slide the panel into the sill trim, making sure to engage the interlock of the panel below. It may be necessary to gently tap the siding panel into place using a hammer and a 2' to 3' long piece of lumber. With this technique, face nails will not be required.

VERTICAL SIDING

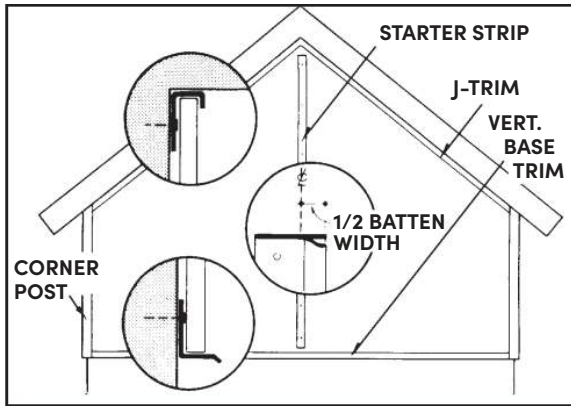

APPLICATION

Vertical siding is used both for an entire installation and as a contrast to horizontal siding, especially on gable ends. Most procedures outlined for horizontal siding are generally the same for vertical siding, except the starter strip is applied vertically and panels interlock in a vertical position.

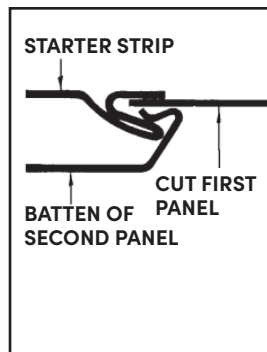
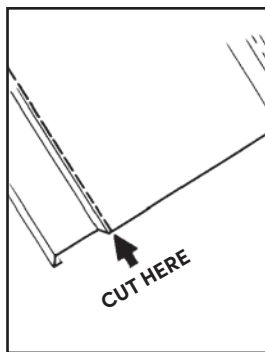

ACCESSORIES AND STARTER STRIP

Snap a chalk line parallel to the eaves or the window heads along the base of the house as a guide for applying vertical-base flashing trim (or J-channel). Apply J-channel under the eaves, adding outside corner bases as required. Trim windows and doors with J-channel on the sides and undersills, using vertical base flashing (or J-channel) at the window heads. To locate the starter strip, drop a plumb line from the gable peak off-center by one half the width of a vertical-panel batten and mark a chalk line. The bottom edge of the starter strip is nailed to this line (see drawing). The raised batten will now be correctly centered for the best appearance.

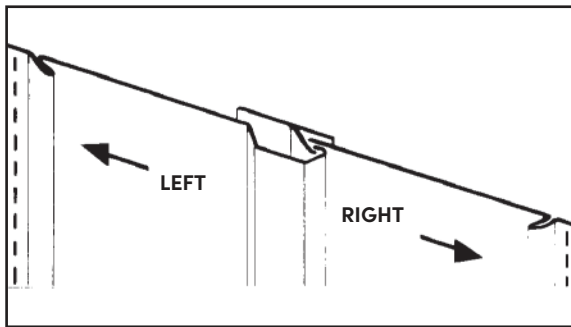

FIRST PANEL

Measure and cut the first panel to the correct length. Cut the batten edge off this panel. Slip the cut edge under the starter strip and nail the panel through the slotted nailing flange. Cut the other panel to the correct length, engage batten flange in the starter strip and nail panel (see drawing).

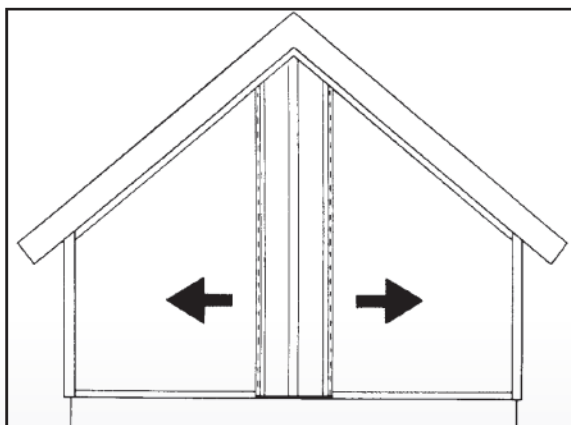

REMAINING PANELS

It will now be possible to continue the installation working both left and right from these two initial center panels (see drawing), making for an even-spaced batten appearance where there is a gable. An alternate way to install the starter strip is to nail it plumb at the corner and install the panels working from only one direction.

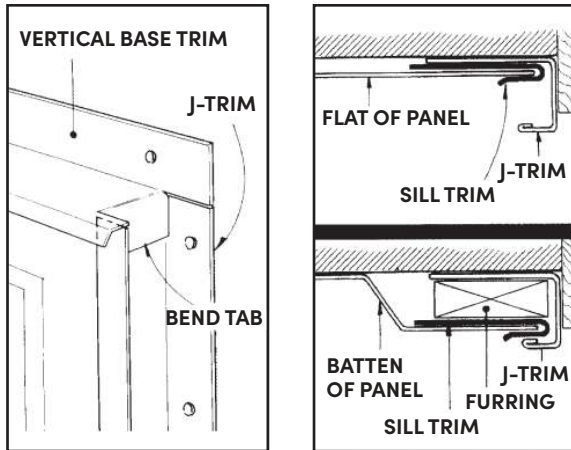

DOORS AND WINDOWS

Panel fitting around door and window trim is similar to that shown for horizontal siding. The cut edge of the vertical panel is capped with sill trim and inserted into a J-channel. Furring out may be required depending on the location of the cut (for instance, if the cut is made in the batten portion of the panel). The procedure at inside and outside corners would be the same as for horizontal siding. The sill trim must be nailed before installing the vertical panel. It can be held in place by punching a notch with a snap-lock punching tool every 12" to 16" at 1/4" from the edge of the panel.

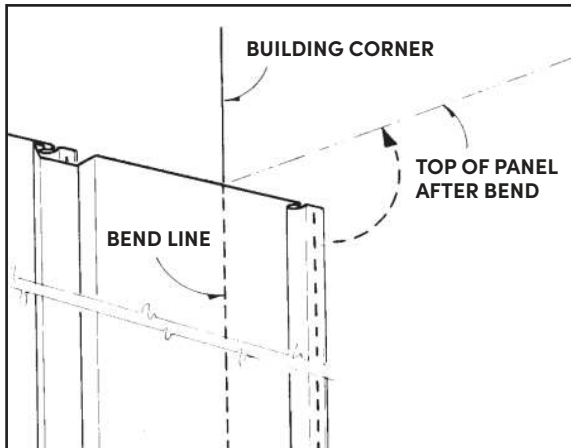

BENT PANEL CORNERS

A panel can be bent around an outside corner rather than using an outside corner base. Cut the panel to the correct length and lock it into the previous panel. Mark where the panel should be bent around the corner and remove it. Use a portable brake and bend the panel to form a right angle. Install the panel and nail it in place. Continue with the next vertical panel on the adjoining wall.

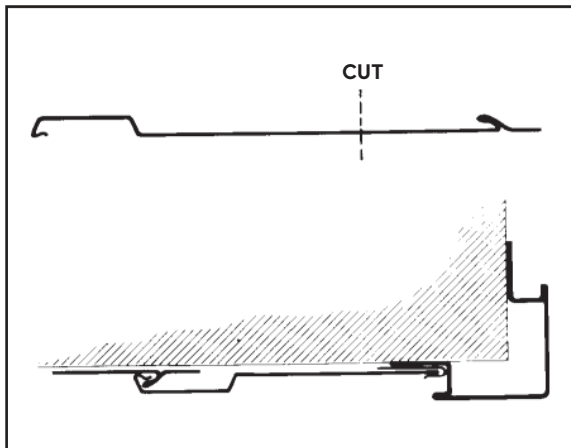

NARROW-CUT PANELS

When panels are cut narrower to fit into corners, at the end of a run, for example, the raw edge can be trimmed using snap-lock finish trim and notching it every 12" to 16" with a snap-lock punching tool at 1/4" from the edge of the panel.

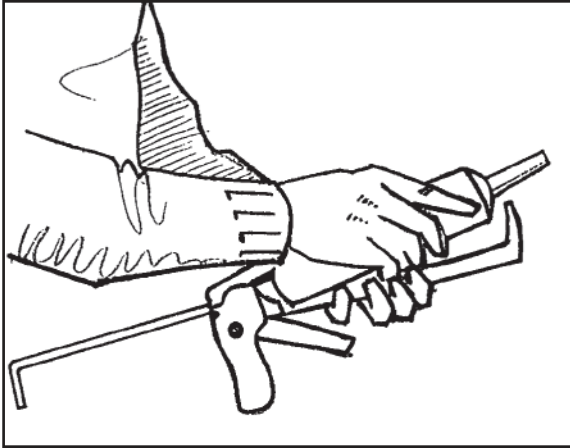

CAULKING

In general, caulking is needed around doors, windows and gables where metal meets wood or metal, except where accessories are used to make caulking unnecessary. Caulking is also needed where metal meets brick or stone around chimneys and walls. Surface caulking must be done neatly at panel cutouts around faucets, meter boxes, etc.

Try not to apply exposed caulking on the tops of siding panels. Also do not caulk the siding inside of a J-channel to attempt to seal it.

It is important to use a deep caulking bead of 1/4" minimum, not just a wide bead. Cut the plastic tip of the caulking cartridge square to get a deeper bead. Move the gun evenly and apply steady, even pressure on the trigger.

Preferred caulking is butyl or silicone type for greater flexibility. Most producers supply caulking in colors to match siding and accessories. Do not depend on caulking to fill large gaps more than 1/8" wide, as expansion/contraction of the siding may cause cracking of the caulking.

CLEANUP

Keep hands as clean as possible or use clean work gloves during application. To remove smudges, use a soft cloth or damp sponge dipped in mild detergent solution or in soap and water. Avoid rubbing too hard, which might create a glossy area on the finish surface. Never use harsh, abrasive cleaners. For asphalt or grease stains, mineral spirits can be used with care. Thoroughly clean off any residue.

JOBSITE

Reinstall all fixtures, brackets, downspouts, etc. removed for the installation. Many applicators paint accessories that weren't replaced, such as kitchen-fan outlets or service cable, to match the color of the new siding. Most manufacturers produce touchup paint or matching paint formulas that can be purchased at local paint stores.

All scrap pieces, cartons, nails, etc. should be removed and the jobsite left neat and clean each day.

Installers should also use a magnet to clean up nails and other metal shavings around the jobsite.

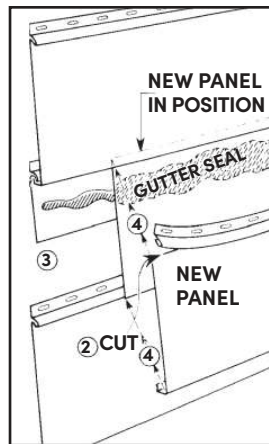
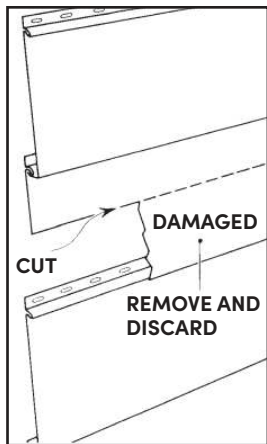

REPLACEMENT OF DAMAGED PANEL

Carefully remove with pry bar or:

1. Cut the entire length of the damaged panel just above the center with tin snips and discard the bottom-cut section. Do not nail into the remaining part of the damaged panel, as this will not allow for expansion/contraction.
2. Remove the top lock of a new panel by cutting it with tin snips. Bend and snap it off. Remove the burrs on the scored edge. Try fitting a small piece of the siding panel under the old lock. If it is too tight, carefully open it with a wide putty knife.
3. Apply a heavy bead of gutter seal the full length of the damaged panel (see drawing).
4. Install the new panel carefully over the gutter seal. Engage the top and bottom of the panel into their respective locks. Be sure the gutter seal makes contact with the new panel. Apply pressure with the palm of your hand. Do not nail the new panel. Use this procedure on all siding.

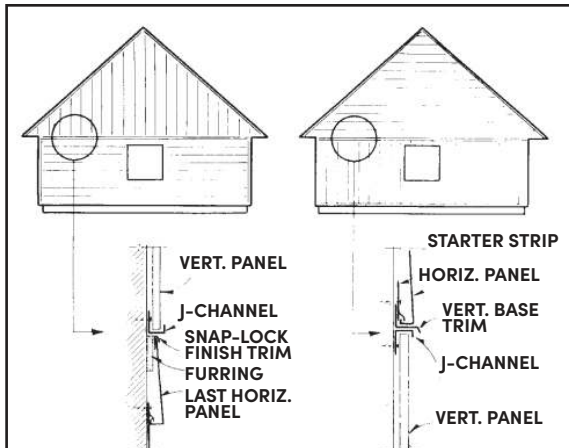

TRANSITIONS

1. **Vertical Over Horizontal** – Cut the nailing flange and lock off the last horizontal panel course, furring it out if necessary. Use sill trim to receive this cut piece. Apply drip-edge molding or J-channel over the top of the horizontal panel to receive the vertical siding. Punch weep holes in the J-channel for water drainage.
2. **Horizontal Over Vertical** – Use J-channel to cap off vertically. Then use vertical base trim and starter strip to start horizontal panels.

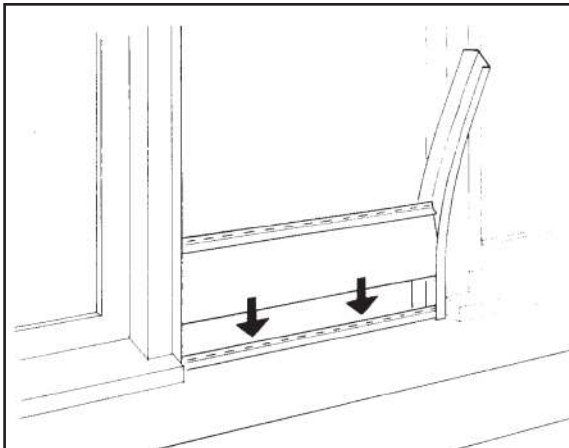

SHORT PANELS BETWEEN OPENINGS

For runs between windows, nail J-channels on both sides of the space. Bow the siding to slip it into the channels. If the space is too narrow to allow the bowing of panels, one J-channel can be left temporarily unattached. It can be nailed in position as successive panels are nailed in place. A nail set may be used to seat nails within the J-channel to prevent damage.

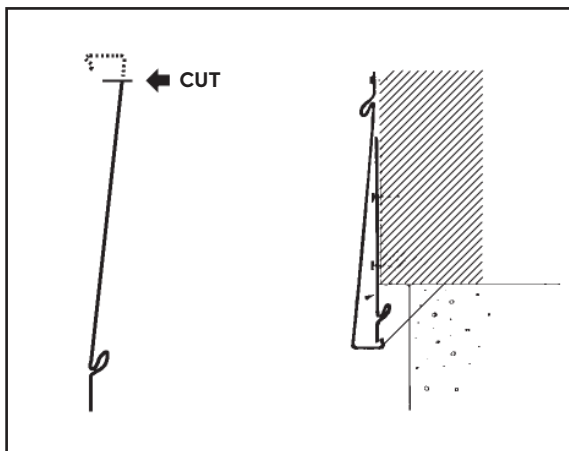

STARTER-STRIP APPLICATION IN DIFFICULT CONDITIONS

This procedure can be used where conventional starter strip is too narrow to fit an uneven base line, or where broken shingles or boards make installing the starter strip difficult or impossible. To solve the problem, cut the butt end from a siding panel and install it upside down, inside out, against the base line of the house. The first-course panel is then engaged in a normal manner as shown.

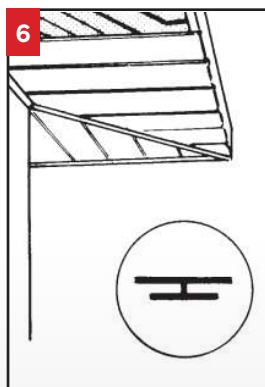
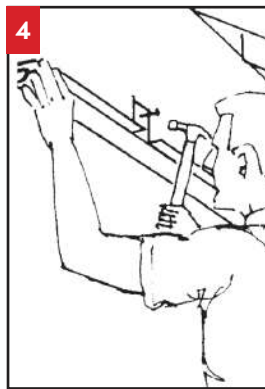
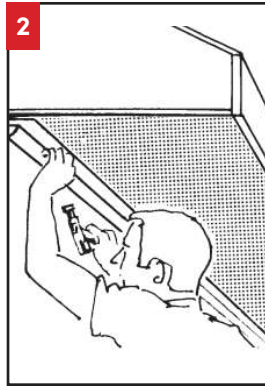
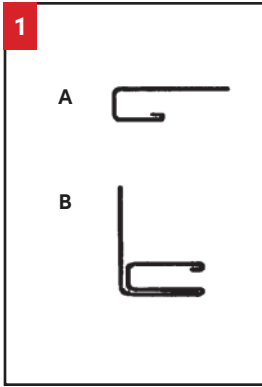

Soffit systems install easily and utilize many of the techniques described previously in this manual. The following steps illustrate the procedure.

WALL RECEIVERS

1. Popular wall receivers used to receive soffit panels are: A) Soffit J-channel; and B) F-channel (reversible frieze).
2. Install one of the wall receivers into existing soffit or outlookers in new construction at the wall line with aluminum nails, which should penetrate 3/4" into solid lumber.
3. If the soffit has open rafters as shown, the wall receiver should be nailed to a chalked line level with the sub-fascia.
4. The wall receiver can be cut with tin snips, and nailing tabs can be bent upward as shown for nailing into the side wall.

NAILING PANELS

Cut panels to the desired length to insert into the wall receiver and align them flush with the outside face of the sub-fascia. Fit panel interlocks together and nail them through using trim or siding nails.

5. Intermediate nails must be placed 24" O.C. Use a pattern of vented/non-vented panels to provide good ventilation from the soffit. Check local building codes for ventilation requirements.

MITER CORNERS

6. When the soffit overhangs on both walls are of equal dimensions, the miter should be installed at a 45° angle to the wall receiver. Cut panels at a 45° angle, slip them into the opening in the miter and nail them in place.

NOTE:

Ribs or grooves should be installed to align at the miter.

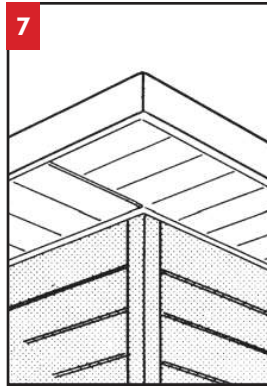

SQUARE CORNERS

7. When the overhang dimensions are not equal on both sides, install the miter molding parallel with the largest dimensions. Ribs or grooves will not align in this application.

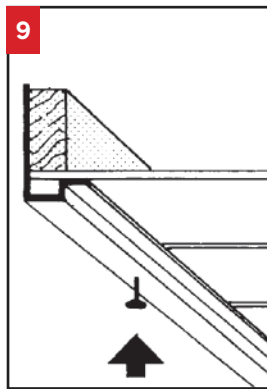

FASCIA

Various styles and height dimensions are available.

8. Never face nail **steel** fascia. Face nailing can result in a wavy or buckled appearance during thermal expansion cycles. Always use a drip edge, gutter or snap-lock finish trim to receive the cut top edge of the fascia. If face nailing is the only option, pre-drill holes larger than the nail.
9. Nail the underside of the fascia as shown. Align the nails with the soffit V-grooves for the best appearance. Nail every 24" but not too tight.

Many times it is necessary to use trim sheet bent on a portable brake to form special fascia shapes. Nail special fascia the same way as described above. Nails should penetrate to a minimum of 3/4".

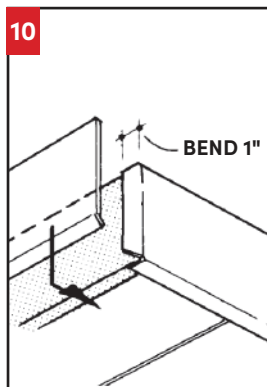

OUTSIDE-CORNER FASCIA

10. Bend a 1" flange 90° around the corner of the first fascia piece. Cut overlapping fascia at a 45° angle. Nail with appropriate-colored trim nails.

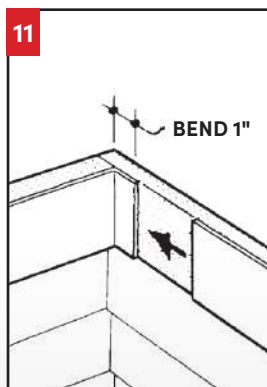

INSIDE CORNER FASCIA

11. Use the same technique as for an outside corner.



GUTTERS

Standard-type gutters as well as newer free-floating systems that reduce the chances of buckling and leakage due to contraction and expansion are available. Always use appropriate nails or screws for gutter brackets. Join gutter sections with pop rivets and gutter-seal mastic.

Gutter can be installed level or sloped for drainage. If sloped on long runs, locate the high spot in the center of the run and pitch the gutter downhill to the downspouts at the corners. The gutter or hangers should be installed to a straight chalk line. After measuring and cutting, assemble one section at a time for the best fit on the fascia. If the gutter is assembled on the ground, make sure the sections are straight.

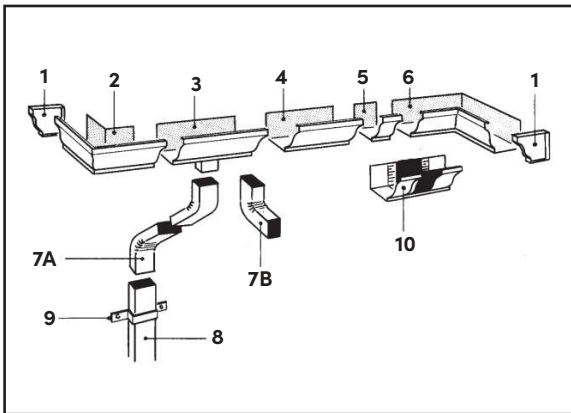

TYPICAL COMPONENTS:

- | | |
|--------------------------|--------------------------------|
| 1. End Cap | 7A. Elbow – Style A |
| 2. Outside Miter | 7B. Elbow – Style B |
| 3. End Piece With Outlet | 8. Downspout or Conductor Pipe |
| 4. Gutter Section | 9. Pipe Strap |
| 5. Slip-Joint Connector | 10. Expansion Joint |
| 6. Inside Miter | |

Hanger systems (see page 35) as well as various fascia-apron systems are also available.

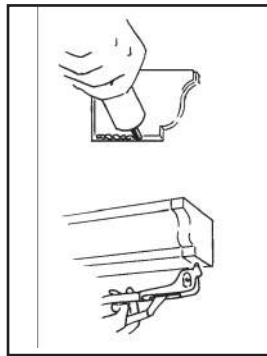

WATERPROOFING

Gutter seal all sections as they are assembled to prevent leaks. Also secure joints with pop rivets, and again apply gutter seal over the riveted joint.

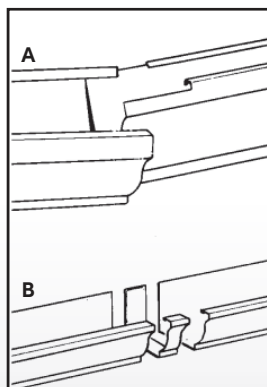

JOINING GUTTER SECTIONS

Gutter sections should be lapped 1-1/2" to 2", with the top front bead and rear hook notched out as shown. Slip the notched gutter into the other section, creating a step down toward the downspout. Apply gutter seal between the overlaps and pop rivet the pieces together (see Fig. A). Expansion joints should be provided on runs exceeding 40' or where gutter is restricted, such as hip or U-shape roofs. When installing in cold weather, allow a 1/2" gap in the notches on the front and rear beads for expansion.

An alternate splice method is the use of slip-joint connectors (see Fig. B). Also use a gutter-seal mastic.

GUTTER HANGERS

There are a great variety of gutter-hanger styles and arrangements. Some fasten to the fascia board, and some wrap around the gutter and secure by straps nailed under the roof shingles. Free-floating gutter systems generally use the fascia board mounting method using a concealed bar bracket. Variations include fascia and roof aprons. Fascia brackets are generally spaced at approximately 32" so the nail penetrates the rafter ends when the appropriate 1-1/4" screw shank nails are used. Roof-hanger types should be nailed through sheathing and into the rafters located at every other rafter (32" maximum).

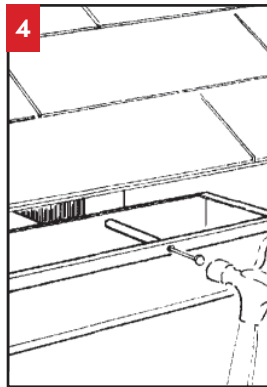
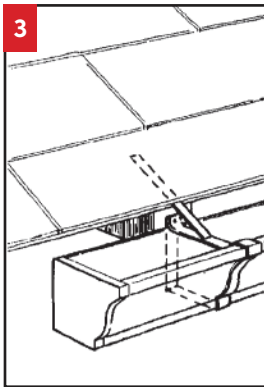
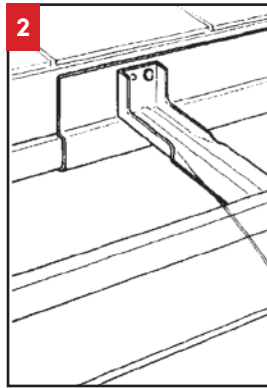
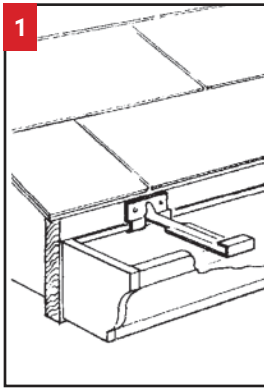

MOUNTING METHODS

1. A combination hanger used with a free-floating system is shown in Fig. 1. This is a concealed fascia-mounted hanger that hooks into front and rear gutter beads.
2. A variation shown in Fig. 2 features a combination bar hanger and fascia apron for more flashing at the back.
3. A wraparound hanger with roofing strap is shown in Fig. 3. This traditional style is often used with open rafter ends and should be nailed under roof shingles at the rafter location.
4. Fig. 4 shows the spike-and-ferrule mounting. Insert a ferrule between the gutter sides aligned with the rafter end. Drive the gutter spike through the gutter and ferrule, and into the rafter end located at every other rafter.

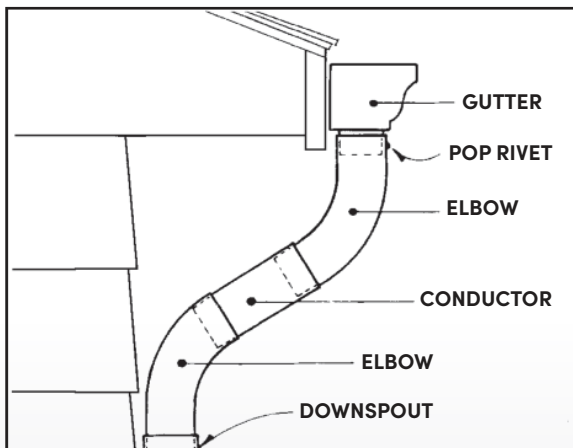

DOWNSPOUTS

Downspouts are installed after gutter is hung, and should be flush with the wall for maximum support. Downspouts, elbows and outlet tubes should be hooked together using self-tapping sheet-metal screws. Locate the drop outlets in the gutter immediately above the downspout locations. Score and remove a piece of gutter bottom the same size as the downspout. Insert the drop tube through this hole and apply self-tapping sheet-metal screws and gutter sealer from the inside. Elbow and downspout sections should always slide inside the section immediately below it to prevent leakage. Use enough outlets and downspouts to handle water from the roof. A 2" x 3" downspout can normally accommodate 600 sq. ft. of roof area, and a 3" x 3" downspout 1,200 sq. ft. Secure downspouts to the house with pipe straps, using two per 10' length.

ESTIMATE WORKSHEET

SIDING

Walls	sq. ft.
Gable ends	sq. ft.
Dormer	sq. ft.
Total wall area – subtract large unsided areas (sliding glass doors, etc.)	sq. ft.
Minus	sq. ft.
Total net areas	sq. ft.
Total net square feet ÷ 100 =	<input type="text" value="squares of siding"/>

ACCESSORIES

Starter strip	lineal ft.
J-channel	lineal ft.
Snap-lock finish trim	lineal ft.
Outside corner post	lineal ft.
Inside corner post	lineal ft.
Soffit panels	panels
Fascia trim	lineal ft.
Undersill trim	lineal ft.
Trim coil	lineal ft.
Gutter coil	lineal ft.
Downspouts	lineal ft.
Perforated foil	lineal ft.
Trim nails	lineal ft.

NOTE:

Add 10% to measurements for waste. Also see Material Estimating on page 7.

Copy this worksheet as needed.